

6

5

4

3

2

1

D

D

C

C

B

B

A

A

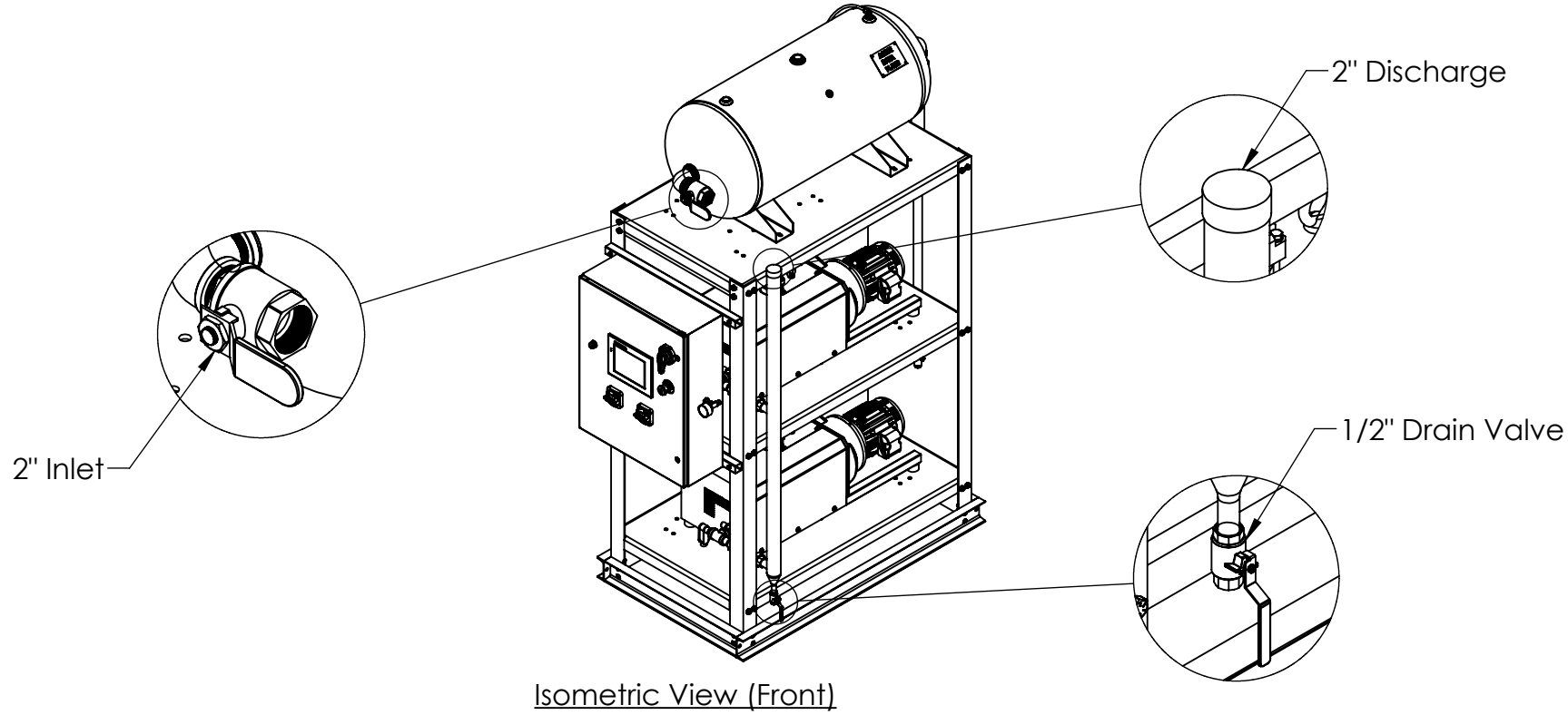

Isometric View (Front)

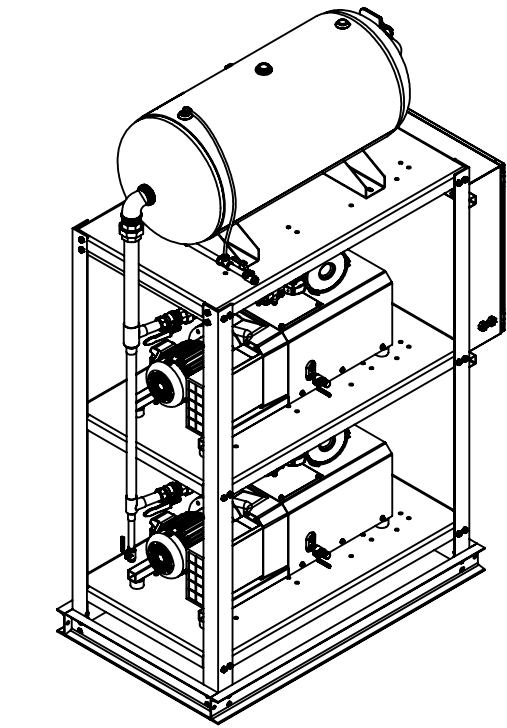

Isometric View (Back)

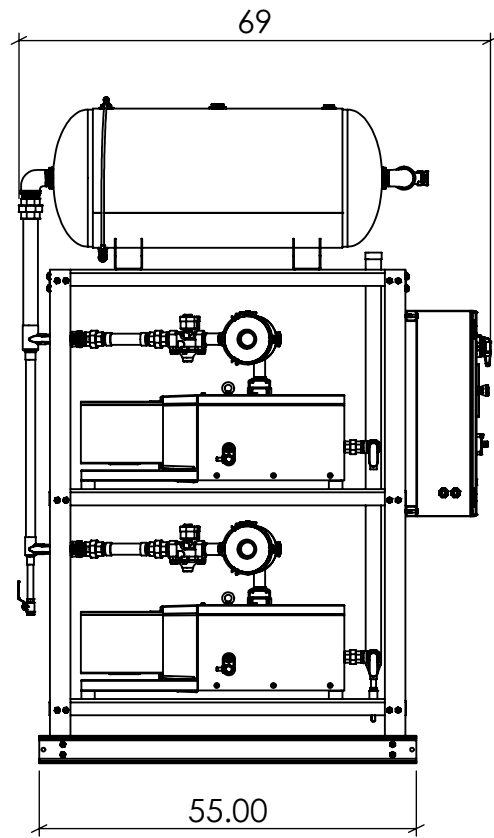

Left View

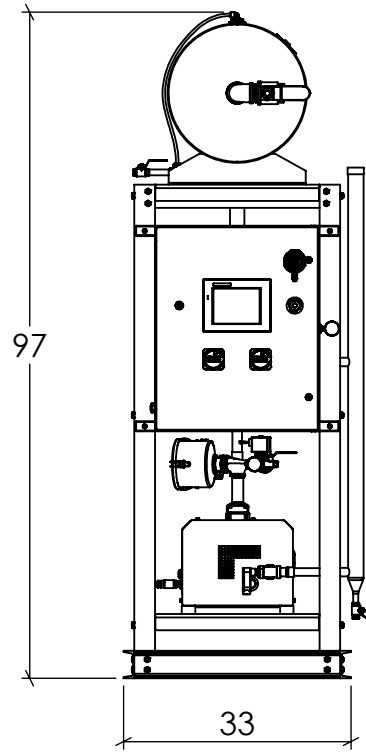

Front View

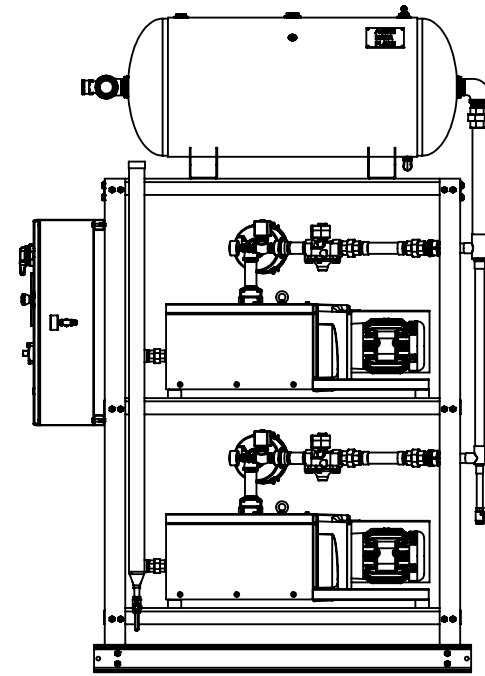

Right View

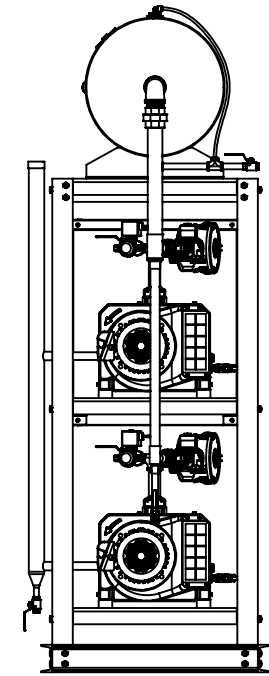

Back View

THIS DRAWING AND INFORMATION CONTAINED IN THIS DRAWING ARE CONFIDENTIAL PROPERTY OF AIR ENERGY GROUP. NO PART OF THIS DRAWING OR ANY INFORMATION CONTAINED IN THIS DRAWING MAY BE REPRODUCED OR TRANSFERRED WITHOUT THE WRITTEN PERMISSION OF AIR ENERGY GROUP.



DRAWN BY
SSC
DATE
6/25/2024

NOTE:
All dimensions in
Inches unless
otherwise noted

DESCRIPTION
Duplex 2 HP Lab Claw
Skid Assembly

PART NO.
VC02F-XXL-06H

SCALE: 1:28

REV. SIZE
B

SHEET: 1 of 2

6

5

4

3

2

1

6

5

4

3

2

1

1

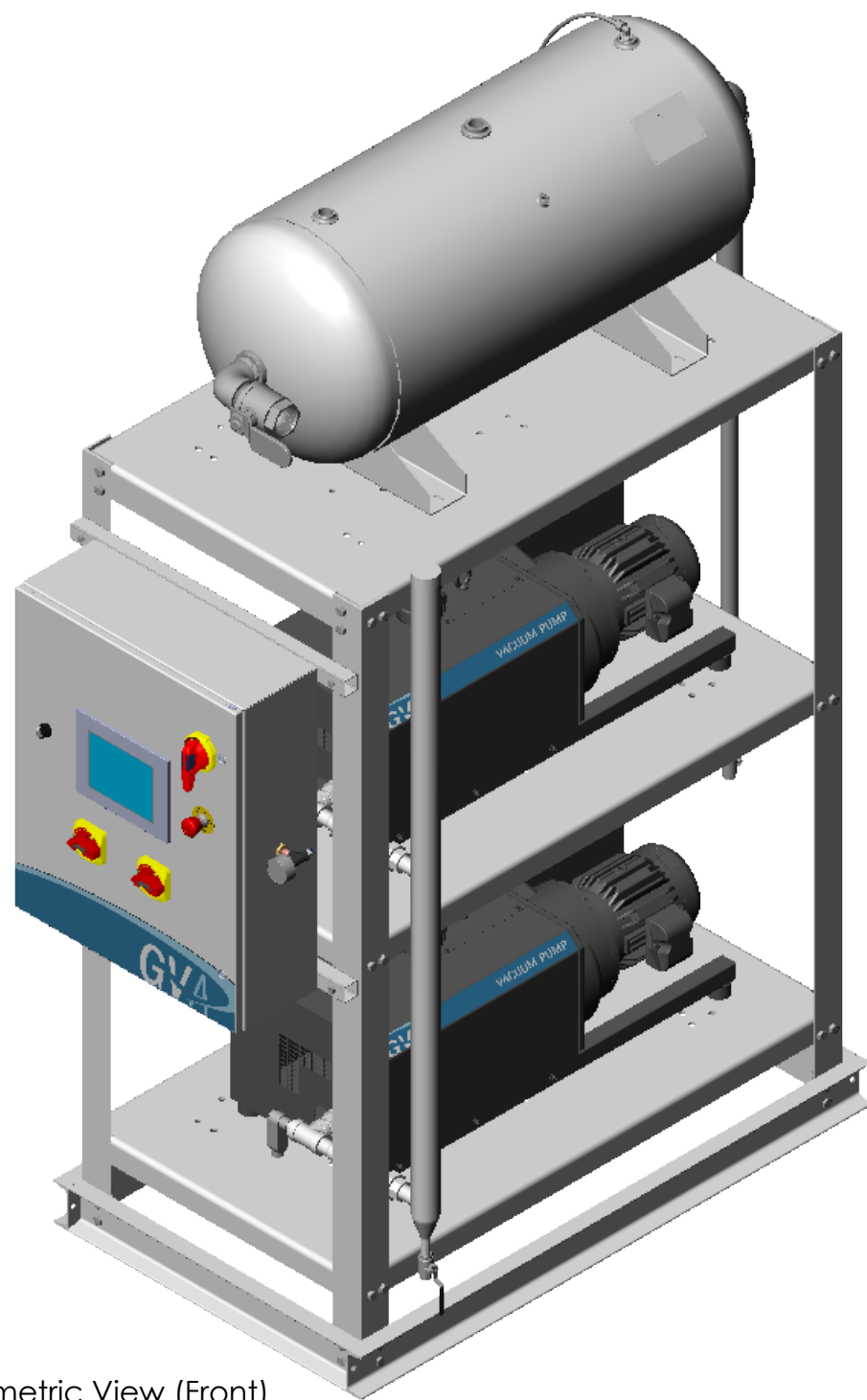

Isometric View (Front)

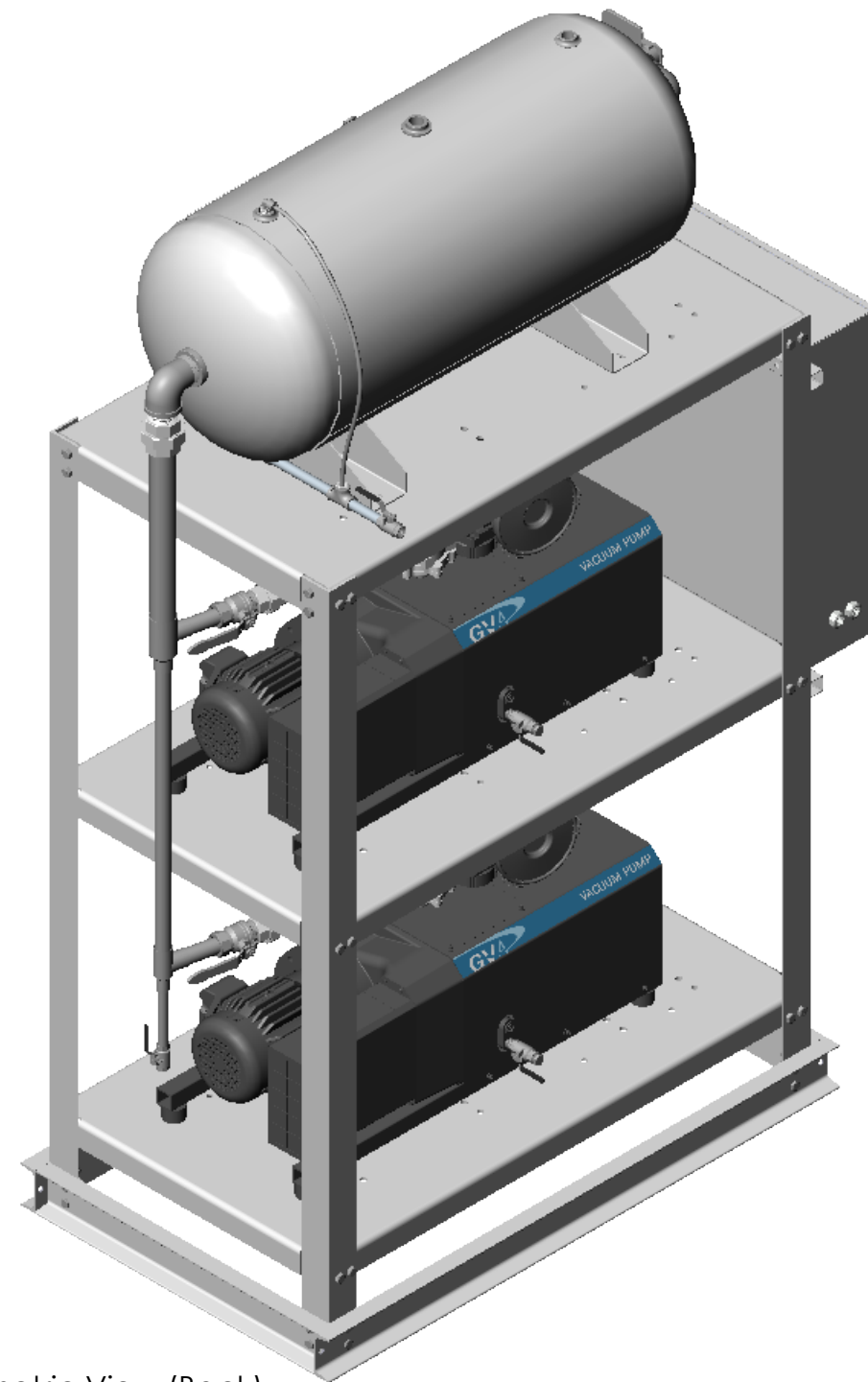

Isometric View (Back)



DESCRIPTION
Duplex 2 HP Lab Claw
Skid Assembly

DRAWN BY
SSC

DATE
6/25/2024

NOTE:
All dimensions in
Inches unless
otherwise noted

PART NO.
VC02F-XXL-06H

SCALE: 1:14

REV. SIZE
B

SHEET: 2 of 2

THIS DRAWING AND INFORMATION CONTAINED IN THIS DRAWING ARE CONFIDENTIAL PROPERTY OF AIR ENERGY GROUP. NO PART OF THIS DRAWING OR ANY INFORMATION CONTAINED IN THIS DRAWING MAY BE REPRODUCED OR TRANSFERRED WITHOUT THE WRITTEN PERMISSION OF AIR ENERGY GROUP.

6

5

4

3

2

1

1